

▲ **Residential Roofs.** Mount flush on a pitched roof where aesthetics are critical.

▶ **Commercial Roofs.** Install at a low slope, remaining invisible behind a parapet.

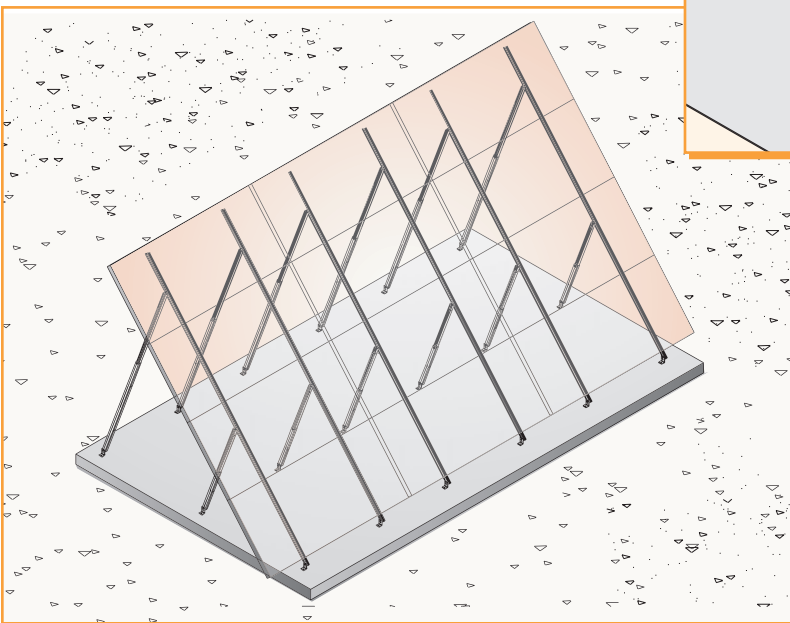
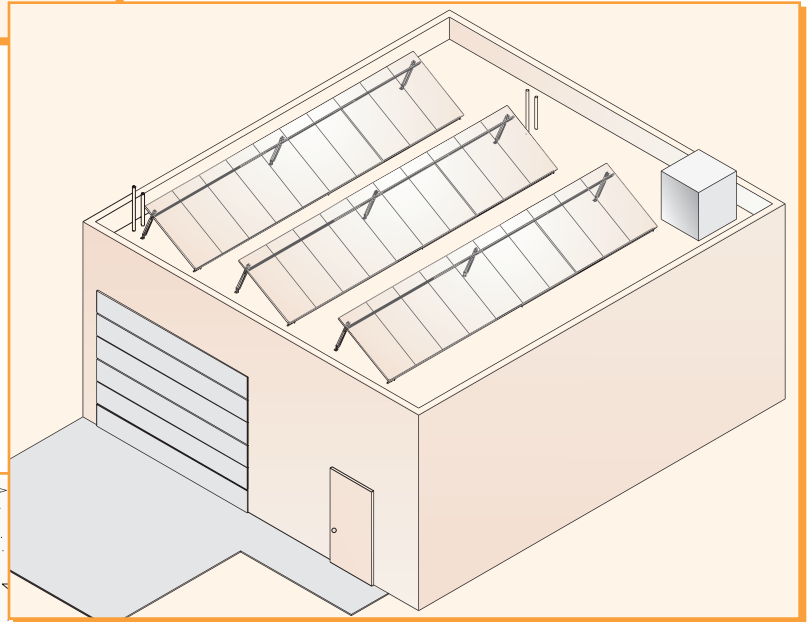

◀ **Ground Mounts.** Base an array on any type of footing or pad.

A Configuration for Any Location

The SolarMount system (patent pending) is engineered for the maximum flexibility possible in designing, locating, and installing your PV array.

On the roof or on the ground, SolarMount components assemble into structures that support a variety of PV array configurations. Design for high profile or low — whichever suits your unique site — without worries that it won't meet code.

Versatile Components Give You Choices

The choice is yours. Attach your modules directly to SolarMount on the roof, or pre-assemble modules and rails and attach to the footings afterward.

SolarMount Rails — the heart of the system. Four mounting slots in the SolarMount rail give you ultimate flexibility for module mounting and foot placement. Clamp modules to the rails from the top, freeing yourself from the constraint of the module mounting holes. Or clip and bolt modules from the bottom to either side of the rail. The footing bolt slot gives you complete freedom of footing placement. You'll always be able to hit the rafter.

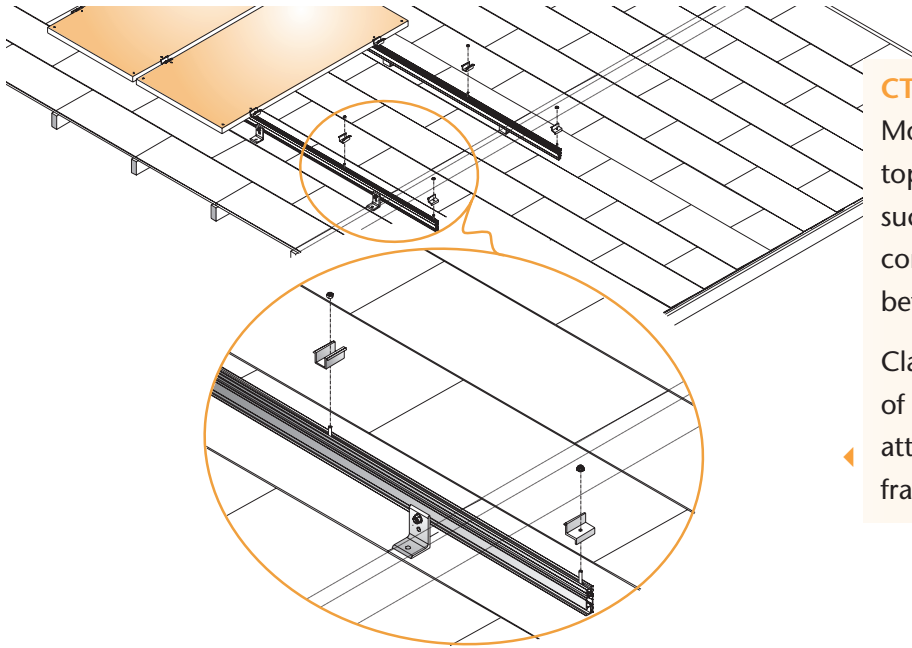
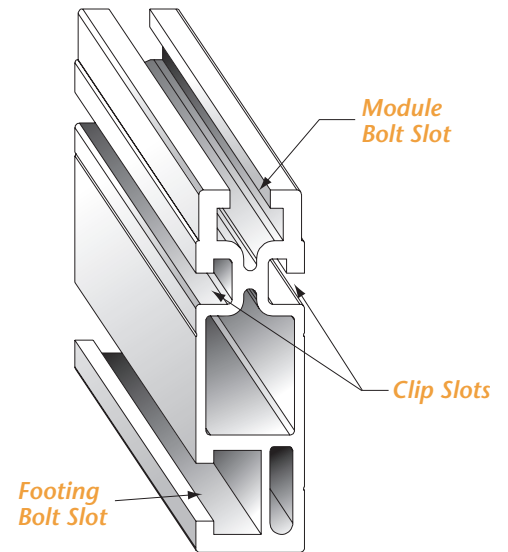

CT Series Top Mounting Clamps.

Mount your modules to the rail from the top. This is ideal in flush mount applications, such as residential rooftops, where it is most convenient to preassemble rails and footings before installing modules.

Clamps also free you from the constraints of module mounting holes. Achieve a secure attachment anywhere along the module frame.

CB Series Bottom Mounting Clips.

Use CB Series clips whenever you prefer to attach rails directly to the module mounting holes. Simply drop the clip into its rail slot over the mounting hole and attach with the mounting bolt for a secure connection.

Adjust the clip position anywhere within the rail slot. Alignment of rails to module mounting holes is always easy and convenient.

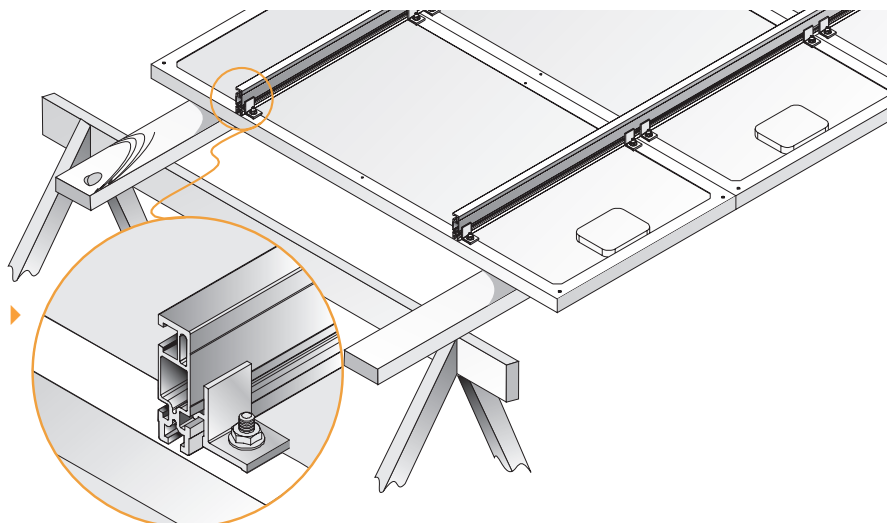

Flexible Components Speed Installation

Whether your array is ground mounted or roof mounted, flush mounted or tilted up, there are SolarMount footings and legs to meet your needs.

Strut-in-tube style tilt legs quickly adjust to the precise tilt angle required. Two styles are available — **TLH Series** for high profile installations and **TLL Series** for low profile. Each series offers three leg lengths so that you can adjust to exactly the tilt angle you want — up to a maximum of 60 degrees — without cutting and drilling at the job site.

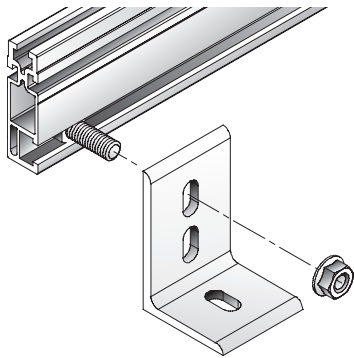
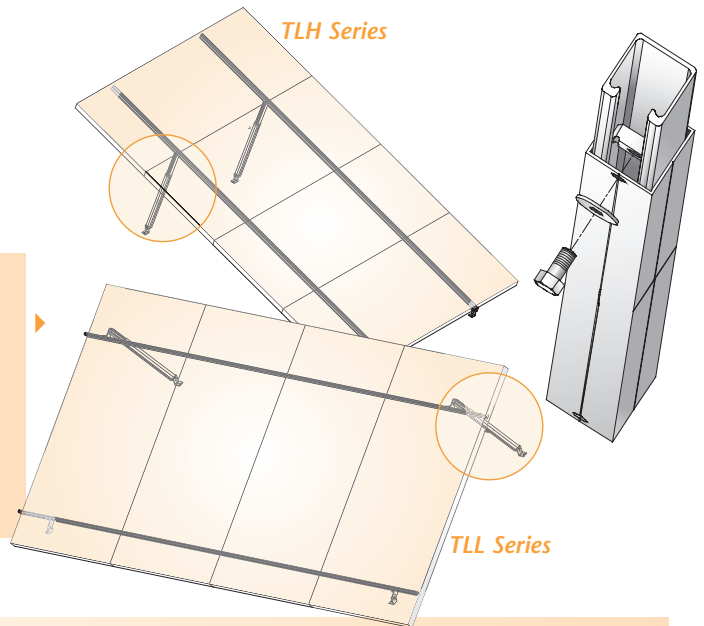

L-feet are standard for ground mount installations. Use them in many residential rooftop installations as well, particularly with asphalt composition shingles, and in many commercial roofing applications.

Rail mounting holes are at two heights. In flush mounts, use the upper hole to raise the modules and promote air flow for cooling. Where aesthetics are the greater concern, use the lower hole to keep the modules close to the roof.

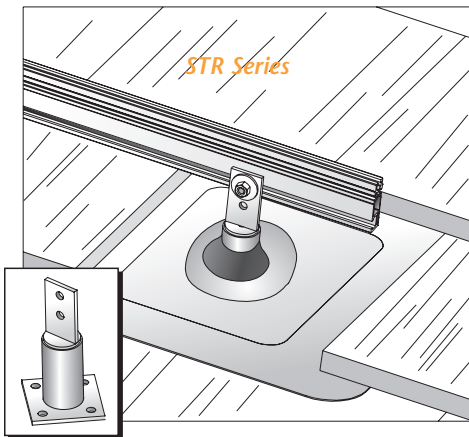

Standoffs are used whenever flashed installations are required — tile roofs for instance. All standoffs, 3 or 6 inches tall, are compatible with Oatey® 1/4-inch No-Calk™ elastomer collared flashings and other non-collared flashings. See www.oatey.com for flashing details.

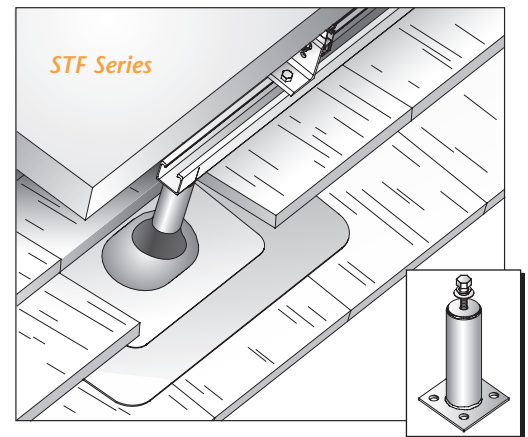

STR Series raised-flange standoffs replace standard L-feet, and fasten directly to SolarMount rails. **STF Series** flat-top standoffs support strut stringers that fasten to standard L-feet, a typical technique on large flat roofs.

Code Compliance. The SolarMount system is PE certified to meet the Uniform Building Code. Our guidelines, *Code-Compliant SolarMount Installation*, provide standards and installation procedures, all thoroughly documented for your building inspector. Call us for a copy, or download it from www.unirac.com.

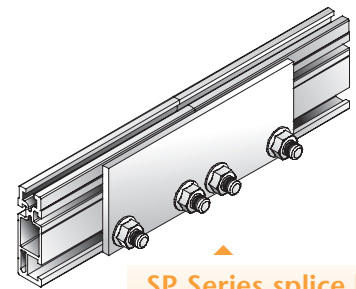

SP Series splice kits join rails end-to-end in long low-profile installations.

PV Module Compatibility List

Call UniRac or your PV dealer for any module not listed.

ASE	ASE300
AstroPower	AP65, AP75, AP110, AP120, AP150
BP Solar	275, 380, 585, 850, 3160, 4160, 5170, MSX120, SX75TU, SX110, SX120, SX150
Evergreen	EC94, EC102, EC110
Kyocera	KC70, KC80, KC120, KC158G
Photowatt	PW750, PW1000, PW1250, PW1650
Sanyo	HIT167, HIT175, HIT180 (with top-mounting clamp only)
Sharp	80, 123, 165 (Schott), 175
Shell (Siemens)	SM100, SM110, SP65, SP70, SP75, SP130, SP140, SP150
SunWize	SW85, SW90, SW95, SW115, SW120
UniSolar	US64, US116

Plan Your Array

Consult the SolarMount Sizing and Price List for complete configuration details. Call UniRac or your PV dealer for a copy, or download from www.unirac.com.

SolarMount Component Specifications

- SolarMount rails, top-mounting clamps, bottom-mounting clips, tilt legs, and L-feet—6105-T5 aluminum extrusion.
- Three-inch and six-inch standoffs—Grade 5 zinc-plated, welded steel.
- Fasteners—304 stainless steel

10 Year Limited Warranty

UniRac, Inc., warrants to the original owner at the original installation site that SolarMount PV Module Mounting System (the "Product") shall be free from defects in material and workmanship for a period of ten (10) years from the earlier of 1) the date the installation is complete, or 2) 30 days after the purchase of the Product by the original owner. This warranty does not cover damage to the Product that occurs during shipment, or prior to installation.

If within such period the Product shall be reasonably proven to be defective, then UniRac shall repair or replace the defective Product, or part thereof, at UniRac's sole option. Such repair or replacement shall fulfill all UniRac's liability with respect to this warranty.

This warranty shall be void if installation of the Product is not performed in accordance with UniRac's Installation Instructions for the Product, or if the Product has been modified, repaired, or reworked in a manner not authorized by UniRac in writing, or if the Product is installed in an environment for which it was not designed. UniRac shall not be liable for consequential, contingent, or incidental damages arising out of the use of the Product.

UNI RAC®

THE NEW STANDARD IN PV MODULE RACKS™

UniRac, Inc.
3201 University Blvd. SE, Suite 110
Albuquerque NM 87106-5635 USA
Phone: 505.242.6411
Fax: 505.242.6412
info@unirac.com
www.unirac.com